

**Notification of the Ministry of Industry
(No.2629) B.E.2543(2000)
issued under the Industrial Product Standards Act B.E.2511(1968)
Subject: Amending to Thai Industrial Standard for
Motorcycle exhaust muffler (Amendment No.2)**

Whereas it is deemed expedient appropriate to revise the Thai Industrial Standard for Motorcycle exhaust muffler (TIS 341-2542).

By virtue of Section 15 of the Industrial Product Standards Act B.E.2511 (1968), the Minister of Industry hereby issues a notification amending the Thai Industrial Standard for Motorcycle exhaust muffler (TIS 341-2542) which is attached to the Notification of Ministry of Industry No.2493, B.E.2542(1999) dated 26 March, B.E.2542 (1999) as follows:

1. The number of the standard is amended from "TIS 341-2542" to "TIS 341-2543".
2. The statement in clause 5.2 is withdrawn and replaced with the following statement:
"5.2 Noise level
The maximum noise level emitted from the exhaust muffler assembled to the subjected which is stationary and operated under normal condition shall not exceed 95 dBA
Testing shall be as directed in clause 8.3."

This ministerial notification shall come into force 180 days as from the day following the date of its publication in the Government Gazette.

Given on 7 February B.E.2543 (2000)
Minister of Industry

Published in the Government Gazette Vol.117, Special Part 54 ngor., dated 6 July B.E.2542 (1999)

Unofficial Translation

In the event of any doubt or misunderstanding arising from this translation, the standard in Thai will be held to be authoritative

**Notification of the Ministry of Industry
(No.2493) B.E.2542(1999)
issued under the Industrial Product Standards Act B.E.2511(1968)
Subject: Amending to Thai Industrial Standard for
Motorcycle exhaust muffler (Amendment No.1)**

Whereas it is deemed expedient appropriate to revise the Thai Industrial Standard for Motorcycle exhaust muffler (TIS 341-2528).

By virtue of Section 15 of the Industrial Product Standards Act B.E.2511 (1968), the Minister of Industry hereby issues a notification amending the Thai Industrial Standard for Motorcycle exhaust muffler (TIS 341-2528) which is attached to the Notification of Ministry of Industry No.949, B.E.2528(1985) dated 21 August, B.E.2528 (1985) as follows:

1. The number of the standard is amended from "TIS 341-2528" to "TIS 341-2542".
2. Table 1 is withdrawn and replaced with the following table:

**Table 1 Thickness of materials for parts of type 2 exhaust muffler
(clause 4.1.2.1)**

Parts of exhaust muffler	Minimum thickness, mm							
	Steel		Zinc-coated steel		Aluminium-coated steel		Stainless steel	
	Engined (stroke)							
	2	4	2	4	2	4	2	4
Exhaust pipe	1.0	1.2	1.0	1.2	0.8	1.0	0.6	0.8
Muffler pipe	0.8	1.0	0.8	0.8	0.6	0.8	0.6	0.8
Muffler shells and baffle					0.6	0.8	0.6	0.8

Notes. - *Where two layers of steel are used, the thickness represents the sum of the thickness of each layer.*

- *For zinc-coated steel and aluminium-coated steel, the thickness is that after coating on both sides.*

3. The statement in clause 5.2 is withdrawn and replaced with the following statement:

"5.2 Noise level

The maximum noise level emitted from the exhaust muffler assembled to the subjected which is stationary and operated under normal condition shall not exceed the following:

5.2.1 95 dBA for motorcycle having capacity from 50 cm³ to 125 cm³;

5.2.2 99 dBA for motorcycle having capacity exceed 125 cm³;

Testing shall be as directed in clause 8.3."

4. The statement in clause 5.3 is withdrawn and replaced with the following statement:

"5.3 Leakage of exhaust muffler

The exhaust gases leaked from the exhaust muffler when subjected to an internal air pressure of approximately 30 kPa at guage pressure shall not exceed 900 cm³/ second.

Testing shall be as directed in clause 8.4."

5. The statement in clause 8.3.2 is withdrawn and replaced with the following statement:

“8.3.2 Microphone positions shall be as illustrated in Figure 2 with the following details:

8.3.2.1 In the case of a vehicle provided with one exhaust outlets the height of the microphone above the ground shall be equal to that of the outlet orifice of the exhaust gases, shall not be less than 0.2 m. The microphone shall be pointed towards the outlet orifice and locked at a distance of 0.5 m from the latter, its axis shall be parallel to the ground and shall make an angle 45° with the vertical plane.

8.3.2.2 In the case of vehicle provided with two or more exhaust outlets spaced not more than 0.3 m apart and connected to a single muffler. The test shall be carried out as prescribed in clause 8.3.2.1, the microphone position shall be related to the outlet orifice nearest to the external side of the vehicle.

8.3.2.3 In the case of vehicle provided with two or more exhaust outlets spaced more than 0.3 m apart and connected to a single muffler, or connected to the other muffler, in any outlet spaced. All outlets orifice shall be carried out as prescribed in clause 8.3.2.2, and the highest level shall be used.

6. The Figure 2 is withdrawn and replaced with the following Figure:

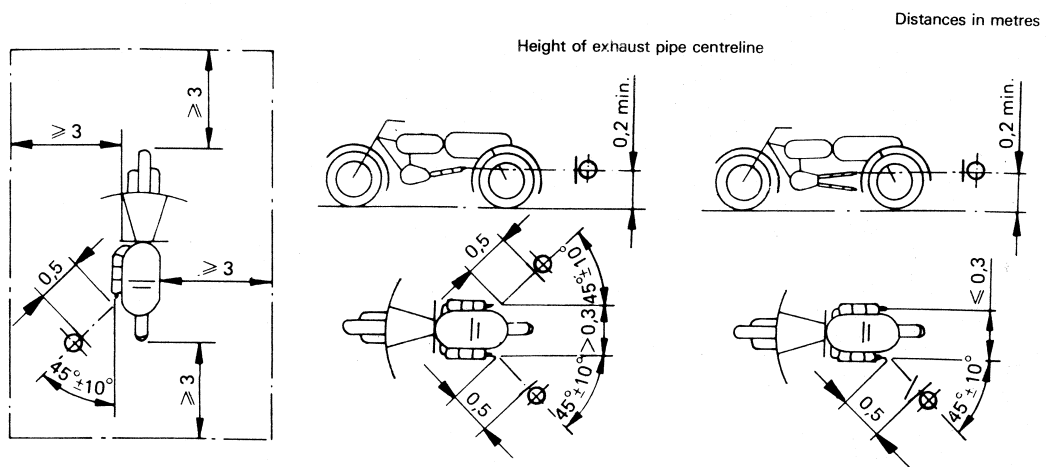

Figure 2 Microphone position
(clause 8.3.2)

7. The statement in clause 8.4 is withdrawn and replaced with the following statement:

“8.4 Leakage of exhaust muffler

The inlet and outlet of the exhaust muffler shall be sealed. Air pressure of approximately 30 kPa at gauge pressure shall be applied into it. Measure are leakage at this pressure.”

This ministerial notification shall come into force 180 days as from the day following the date of its publication in the Government Gazette.

Given on 26 March B.E.2542 (1999)
Minister of Industry

Published in the Government Gazette Vol.116, Special Part 107 ngor., dated 24 December B.E.2542 (1999)

TIS 341-2528(1985)
Thai Industrial Standard
For
Motorcycle Exhaust Muffler

1. Scope

- 1.1 This standard specifies materials, components and workmanship, requirements, mark and label, sampling and criteria for conformity, and testing for exhaust muffler for two-stroke and four-stroke engine in motorcycles excluding racing motorcycles.

2. Definitions

For the purpose of this standard, the following definitions apply:

- 2.1 **MOTORCYCLE EXHAUST SYSTEM** hereinafter referred to as **EXHAUST MUFFLER**: A device which permits the discharge of exhaust gases and reduces the exhaust noise level of internal combustion engine in motorcycles into the atmosphere.
- 2.2 **EXHAUST PIPE**: A pipe which permits the transmission of exhaust gases into the atmosphere.
- 2.3 **MUFFLER**: A device which serves to reduce exhaust noise level.

3. Types

- 3.1 Exhaust mufflers are classified into two types as illustrated in Figure 1.
- 3.1.1 Type 1 : part that emits the flow of exhaust gases and part that reduces exhaust noise level are assembled as an integral component.
- 3.1.2 Type 2 : part that emits the flow of exhaust gases and part that reduces exhaust noise level are visibly two separate components.

4. Materials, components and workmanship

4.1 **Materials**

Materials for the construction of exhaust muffler shall be as follows:

4.1.1 **Type 1 exhaust muffler**

The thickness of steel for muffler body, baffles or reinforcement shall not be less than the following:

4.1.1.1 0.80 mm for two-stroke engine;

4.1.1.2 1.00 mm for four-stroke engine

Compliance is checked by measurement with an instrument accurate to 0.01 mm.

Notes 1. Where two layers of steel are used, the thickness refers to the sum of the thickness of each layer.

2. It is recommended that the minimum thickness of the bracket muffler supports be 2.3 mm.

4.1.2 **Type 2 exhaust muffler**

4.1.2.1 **Thickness**

Parts of the assembly shall be constructed from materials with thickness as specified in Table 1.
Compliance is checked by measurement with an instrument accurate to 0.01 mm.

Table 1
Thickness of materials for parts of type 2 exhaust muffler
(clause 4.1.2.1)

Parts of exhaust muffler	Minimum thickness, mm							
	Steel		Zinc-coated steel		Aluminum-coated steel		Stainless steel	
	Engine (stroke)							
	2	4	2	4	2	4	2	4
Exhaust pipe	1.10	1.28	1.04	1.23	0.86	1.06	0.70	0.88
Muffler pipe	0.90	1.10	0.71	0.84	0.69	0.86	0.70	0.88
Muffler shells and baffle					0.69	0.86	0.70	0.88

- Notes
1. Where two layers of steel are used, the thickness represents the sum of the thickness of each layer.
 2. For zinc-coated steel and aluminum-coated steel, the thickness is that after coating on both sides.

4.1.2.2 Corrosion resistance

When tested as directed in clause 8.1.3, the loss in weight of materials for aluminum-coated steel and stainless steel shall not exceed 88 g/m² of the surface area.

4.1.2.3 Plating adhesion

For zinc-coated steel and aluminum-coated steel when tested in accordance with the method specified in TIS 340, *Exhaust system for car, bus and truck*, the coating shall not peel or scale, and the base material shall not crack.

4.2 Components

It is recommended that exhaust muffler be composed of parts as shown in Figure 1.

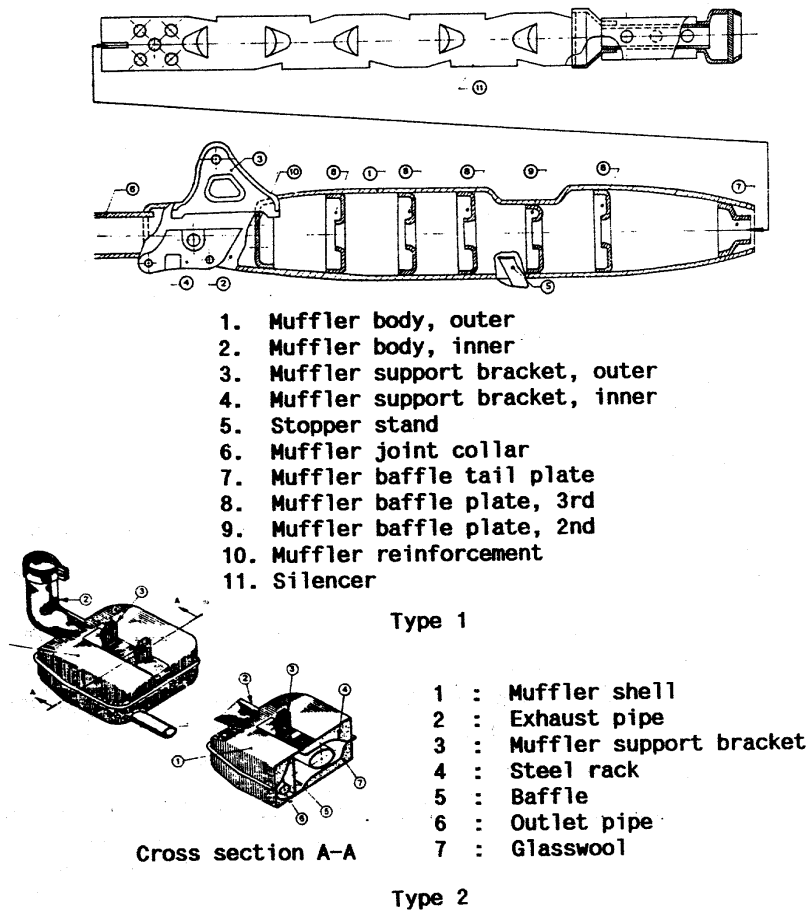

Figure 1 General components of exhaust muffler
(clauses 3.1 and 4.2)

4.3 Workmanship

4.3.1 The product shall be of good appearance, free from rust, deformation and any defect which may affect its serviceability.

4.3.2 For type 2 exhaust muffler, the welded joints shall be cleaned after having been assembled. The welds or the whole assembly shall be thoroughly paint-coated or sprayed.

5. Requirements

5.1 Surface coating

Type 1 exhaust muffler shall be subjected to one of the following surface treatments.

5.1.1 Nickel and chromium plating

The product shall be subjected to double nickel plating followed by chromium plating which may or may not be treated to black chrome.

5.1.1.1 Thickness

The thickness of nickel and chromium coatings shall be not less than 20 μm and 0.15 μm , respectively.

Testing shall be as directed in clause 8.1.2.

- 5.1.1.2 Corrosion resistance
When tested as directed in clause 8.1.3, the loss in weight of materials shall not exceed 88 g/m² of the surface area.
- 5.1.2 Painting
 - 5.1.2.1 Film thickness
The film thickness shall not be less than 25 µm.
Testing shall be as directed in clause 8.2.2.1.
 - 5.1.2.2 Hardness
When tested as in clause 8.2.2.2, there shall be no presence of scratches.
 - 5.1.2.3 Adhesion
When tested as in clause 8.2.2.3, the paint shall not peel.
 - 5.1.2.4 Temperature endurance
When tested as in clause 8.2.2.4, the paint shall not crack, be blistered, burned, broken or peeled off.
 - 5.1.2.5 Corrosion resistance
When tested as in clause 8.2.2.5, there shall be no sign of rust spots at a distance exceeding 3 mm from the cross mark and the paint shall not be peeled off or unsettled.
- 5.2 Noise level
The maximum noise level emitted from the exhaust muffler assembled to the subjected motorcycle which is stationary and operated under normal condition shall not exceed 100 dBA.
Testing shall be as directed in clause 8.3.
- 5.3 Leakage of exhaust muffler
The exhaust gases leaked from the exhaust muffler when subjected to an internal air pressure of approximately 30kPa shall not exceed 1 500 cm³/second.
Testing shall be as directed in clause 8.4.

6. Mark and label

- 6.1 Each exhaust muffler shall bear at least number, letter or mark indicating clearly and legibly the following information:
 - (1) Motorcycle intended for installation of the exhaust muffler (a code may be used upon agreement between the purchaser and the supplier)
 - (2) Name of manufacturer, factory or trademarkIn case foreign language is used, the meaning shall correspond to that in Thai specified above.
- 6.2 Any person who manufactures product conforming to this standard may use the Standards Mark in connection with his product only after having received a licence from the Industrial Product Standards Council.

7. Sampling and criteria for conformity

- 7.1 Definition
 - 7.1.1 Lot: A number of exhaust mufflers for installation in a specified motorcycle which are made from material of the same kind by the same method at a continuous run or those of the same delivery or transaction.
- 7.2 Sampling and criteria for conformity shall be in accordance with the following sampling plan or its technical equivalent.
 - 7.2.1 Sampling for test on material

7.2.1.1 Sample two exhaust mufflers at random from the same lot or sample a steel sheet used for the construction of exhaust muffler approximately 500 mm x 500 mm in size.

(1) For type 1 exhaust muffler, the sample shall be subjected to thickness test.

(2) For type 2 exhaust muffler, the sample shall be subjected to the tests in Table 2.

For zinc-coated steel and aluminum-coated steel sheet, the sample shall be cut parallel to the rolling direction.

For components in the form of pipe, the sample to be taken shall be sufficient for preparation of specimens for all specified test items.

Table 2
Tests on materials for construction of type 2 exhaust muffler
(clause 7.2.1.1(2))

Material	Thickness	Corrosion resistance	Plating adhesion
Steel	✓	-	-
Zinc-coated steel	✓	-	✓
Aluminum-coated steel	✓	✓	✓
Stainless steel	✓	✓	-

7.2.1.2 The lot shall be deemed as conforming to the requirements when, for type 1 exhaust muffler, all specimens meet the requirements of clause 4.1.1, and for type 2 exhaust muffler all the specimens meet the requirements of clauses 4.1.2.1 and 4.1.2.2 and one of the specimens meets the requirements of clause 4.1.2.3.

7.2.2 Sampling for nickel and chromium plating test

7.2.2.1 Take two exhaust mufflers at random from the same lot or take a sample of steel sheets used for the manufacture of exhaust muffler in an amount sufficient to prepare four 50 mm x 75 mm specimens. Then take one extra sample or two extra pieces of specimen for retest on corrosion resistance.

7.2.2.2 The lot shall be deemed as conforming to the requirements when all samples meet the requirement of clause 5.1.1.

7.2.3 Sampling for test on painting

7.2.3.1 Take five exhaust mufflers at random from the same lot or take a sample of steel sheet used for the manufacture of exhaust muffler in an amount sufficient to prepare ten 70 mm x 150 mm specimens.

7.2.3.2 The lot shall be deemed as conforming to the requirements when all the samples meet the requirement of clause 5.1.2.

7.2.4 Sampling for inspections of workmanship, noise level and leakage

7.2.4.1 Take three sets of exhaust muffler at random from the same lot.

7.2.4.2 The lot shall be deemed as conforming to the requirements when all samples meet the requirements of clauses 4.3, 5.2 and 5.3.

7.2.5 Criteria for conformity

Provided all samples meet the requirements of clauses 7.2.1.2, 7.2.2.2, 7.2.3.2 and 7.2.4.2, the lot shall be deemed to comply with this standard.

8. Testing

8.1 Nickel and chromium plating

8.1.1 Preparation of specimens

8.1.1.1 Preparation of specimens from exhaust muffler

Two 50 mm x 75 mm specimens shall be cut from each sample taken as in clause 7.2.2.1 from the area of the least bend and free from welded seams.

8.1.1.2 Preparation of specimens from steel sheet

Four 50 mm x 75 mm specimens shall be cut from the sample taken as in clause 7.2.2.1 and treated by the same plating process as that for exhaust mufflers of that lot.

8.1.2 Plating thickness test

Two specimens as in clause 8.1.1.1 or 8.1.1.2 shall be tested as directed in the Thai industrial standard for electroplating (or, where the said standard has not been promulgated, ISO 1456) or using other equivalent technique. In case of black chrome, the thickness of chromium obtained shall be multiplied by 8.2.

8.1.3 Corrosion resistance test

Two specimens as in clause 8.1.1.1 or 8.1.1.2 shall be tested as directed in TIS 340.

8.2 Paint coating

8.2.1 Preparation of test specimens

8.2.1.1 Preparation of specimens from exhaust muffler

Two specimens 70 mm x 150 mm or of the size as considered appropriate shall be cut from each of the samples taken as in clause 7.2.1.1.

8.2.1.2 Preparation of specimens from steel sheet

Ten 70 mm x 150 mm specimens shall be cut from the sample taken as in clause 7.2.1.1 and treated by the same coating process as for exhaust mufflers of that lot.

8.2.2 Test procedure

8.2.2.1 Film thickness

Two specimens as in clause 8.2.1.1 or 8.2.1.2 shall be subjected to the determination of the film thickness by the method directed in TIS 285, Methods of test for paints, varnishes and related materials : Part 5, Determination of film thickness. Each specimen shall be tested at any five positions and the report shall include the average of each specimen.

8.2.2.2 Hardness

Two specimens as in clause 8.2.1.1 or 8.2.1.2 shall be heated in an oven until dry for at least 3 hours. Using a pencil having a lead with hardness H, diameter not less than 1.8 mm and pointed end of 3 mm length, draw three lines each of which is 20 mm long on the specimen, applying a force of approximately 10 N and holding a pencil at an angle of 45° to the specimen while drawing each line. Then observe for scratches.

8.2.2.3 Adhesion

Two specimens as in clause 8.2.1.1 or 8.2.1.2 shall be tested by the method directed in JIS D 0202.

8.2.2.4 Temperature endurance

Two specimens as in clause 8.2.1.1 or 8.2.1.2 shall be heated in an oven at 300°C for 30 minutes and allowed to stand at room temperature for 30 minutes. Repeat the process 10 times. Observe for any alteration in colour.

8.2.2.5 Corrosion resistance

Two specimens as in clause 8.2.1.1 or 8.2.1.2 shall be diagonalized, using a blade, to mark a cross, and tested as directed in JIS Z 2371 for 8 hours and allowed to stand for 10 hours. Repeat the test one more time and observe for rust spots, peeling-off or unsettlement at a distance exceeding 3 mm from the cross mark.

8.3 Noise emitted by stationary vehicles

The test method shall be as directed in TIS 340 with the following additional details.

8.3.1 Engine operating condition during the test. The engine shall be stabilized at one of the following revolution speed.

8.3.1.1 $1/2 S$ when S exceeds 5 000 rpm.

8.3.1.2 $3/4 S$ when S does not exceed 5 000 rpm.

Where S is the engine revolution at which the engine can produce its maximum power as indicated by the manufacturer.

8.3.2 Microphone positions shall be as illustrated in Figure 2.

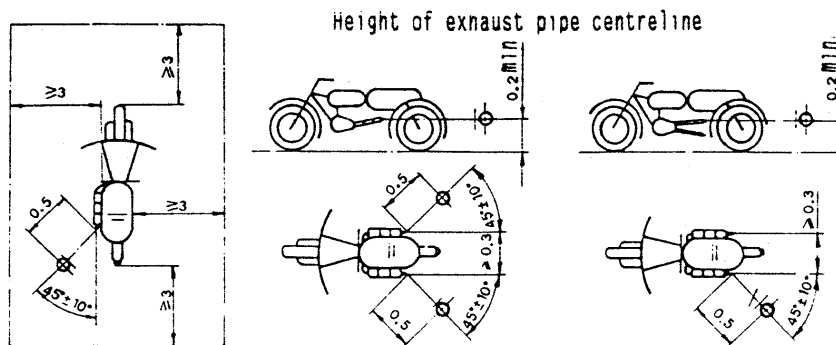

Figure 2 Microphone positions
(clause 8.3.2)

8.4 Leakage of exhaust muffler

The inlet and outlet of the exhaust muffler shall be sealed. Air pressure of approximately 30 kPa shall be applied into it. Measure air leakage at this pressure.